



ByDESIGN Presents the  
**10<sup>th</sup> Annual**  
**CASA Alumni Scholarships**

**College of Environmental Design**  
**University of California**

April 3, 2021



Martin Del Campo . Bob Esparza

& Antonia Escobar Scholarships

A c a d e m i c & C r e a t i v e E x c e l l e n c e

**Welcome!**

**Collaborating for Diversity,  
Equity & Access to Higher  
Education**

By**DESIGN**



**CASA**alumni

UC  
**BERKELEY**  
ENVIRONMENTAL  
DESIGN



CENTER *for*  
ARCHITECTURE + DESIGN

**AIA** **San Francisco**



Martin Del Campo . Bob Esparza

& Antonia Escobar Prizes

A c a d e m i c & C r e a t i v e E x c e l l e n c e

## Evening Program



2018 scholarship recipients

- Introduction of Partners
  - ByDESIGN
  - CASAalumni
  - CED, UC Berkeley
  - CASA, UC Berkeley
  - Latinx in Architecture (LiASF)
  - AIA SF / Center for Architecture + Design
- 10 Year Scholarship Recap
- Scholarships Ceremony

# INTRODUCTIONS





Martin Del Campo . Bob Esparza

& Antonia Escobar Prizes

A c a d e m i c & C r e a t i v e E x c e l l e n c e

## ByDesign e-zine

Rogelio Roy Hernández

President/CEO, ThirdWave Corporation



- Tell untold stories of BIPOC/LGBTQ
- 10 years showcasing extraordinary achievement, thanks to our incredible team of volunteers: Joseph, Martha, Michael, Aymee, and Itzel
- Advocate for educational inclusion
- Link academia with design professions
- Foster community and opportunities



Martin Del Campo . Bob Esparza

& Antonia Escobar Prizes

A c a d e m i c & C r e a t i v e E x c e l l e n c e

## CASA Alumni

Joseph Martinez, Architect, Principal  
Martinez-Cutri Architecture & Planning

- Leverage CASA's 50 Year legacy
- Advance equal access and diversity
- Provided mentoring and guidance with: resumes, portfolios workshops / reviews, interview skills, and grad school applications since 2010
- Provide scholarships since 2011







Martin Del Campo . Bob Esparza

& Antonia Escobar Prizes

A c a d e m i c & C r e a t i v e E x c e l l e n c e

## College of Environmental Design

Despite of our best efforts, we were unable to connect with Dean Chakrabarti





Martin Del Campo . Bob Esparza

& Antonia Escobar Prizes

A c a d e m i c & C r e a t i v e E x c e l l e n c e

## College of Environmental Design

2011



2016



2018

2014

**We'd like to recognize  
previous dean, Jennifer Wolch**

For 10 years of engagement:

- Attended scholarship events
- Welcomed attendees to the event
- Provided use of the 1<sup>st</sup> floor gallery
- Provided food and refreshments
- Advertised the event at CED
- Posted ByDESIGN on the CED Website
- Donated to the scholarships!

***Thank you for your extraordinary support of diversity compañera!***





Martin Del Campo . Bob Esparza

& Antonia Escobar Prizes

A c a d e m i c & C r e a t i v e E x c e l l e n c e

## CASA

Michelle Hernandez, President

Samantha Andalon, Vice President



- Devoted to promoting diversity and equality, the importance of higher education and service to our community
- Build a sense of belonging at CED
- Plan and execute a variety of programs to assist Chicanx/Latinx students succeed at CED
- All areas of study welcomed!



Martin Del Campo . Bob Esparza

& Antonia Escobar Prizes

A c a d e m i c & C r e a t i v e E x c e l l e n c e

## LiA SF (Latinx in Architecture)

Homer Perez, AIA, 2021 Chair  
Sr. Store Design Manager, Sephora

Patricia G. Alarcón, AIA, Co-chair  
Associate Principal, Ratcliff

Patricia Centeno, AIA, LiA Board Liaison  
Associate Principal, BAR Architects





Martin Del Campo . Bob Esparza

& Antonia Escobar Prizes

A c a d e m i c & C r e a t i v e E x c e l l e n c e

## AIA SF

CENTER *for*  
ARCHITECTURE + DESIGN



Amy Ress  
Director

Daniel Perez, AIA  
Principal, Studio Perez  
AIASF Board Treasurer 2021



# 10 YEAR SCHOLARSHIP RECAP





Martin Del Campo . Bob Esparza

& Antonia Escobar Prizes

A c a d e m i c & C r e a t i v e E x c e l l e n c e

# 10 Years Supporting Students

2011 – 2018: Cash Awards	45,000
Tech: Laptops & Software*	8,000
Cars (2)*	16,000
2021	7,350
2021*	250
<hr/>	
	<b>\$ 76,600</b>

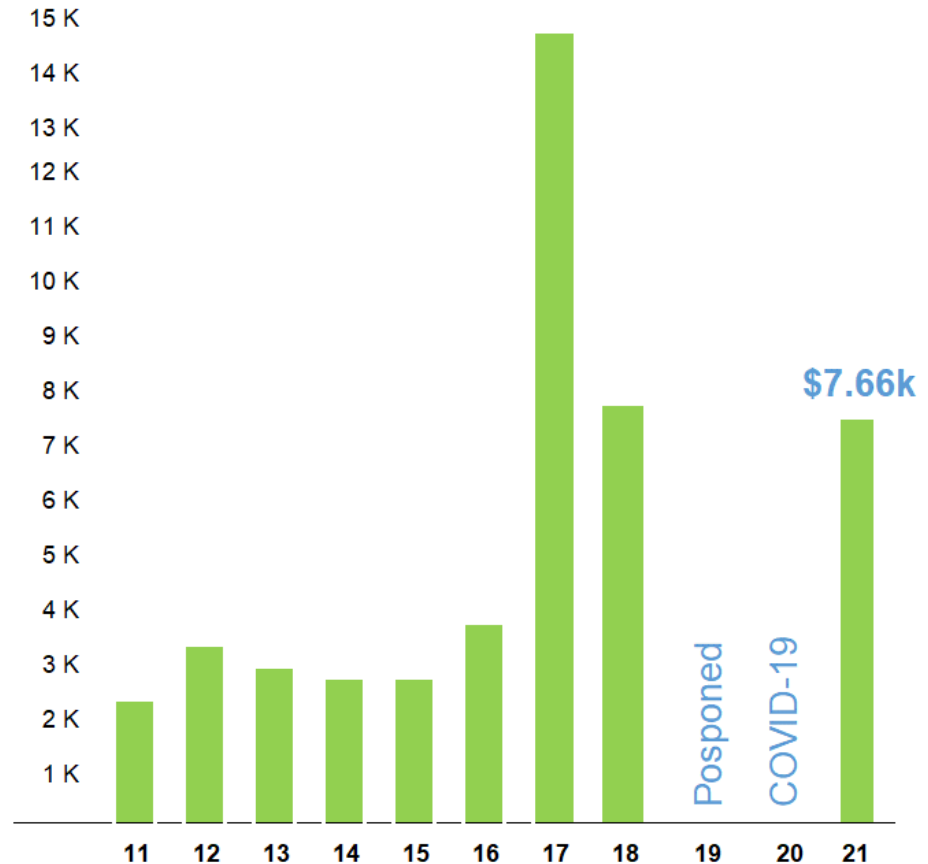

\* Awarded outside of CAD/AIASF 501 (c) (3)



Martin Del Campo . Bob Esparza

& Antonia Escobar Prizes

A c a d e m i c & C r e a t i v e E x c e l l e n c e

## Scholarships by Area of Study

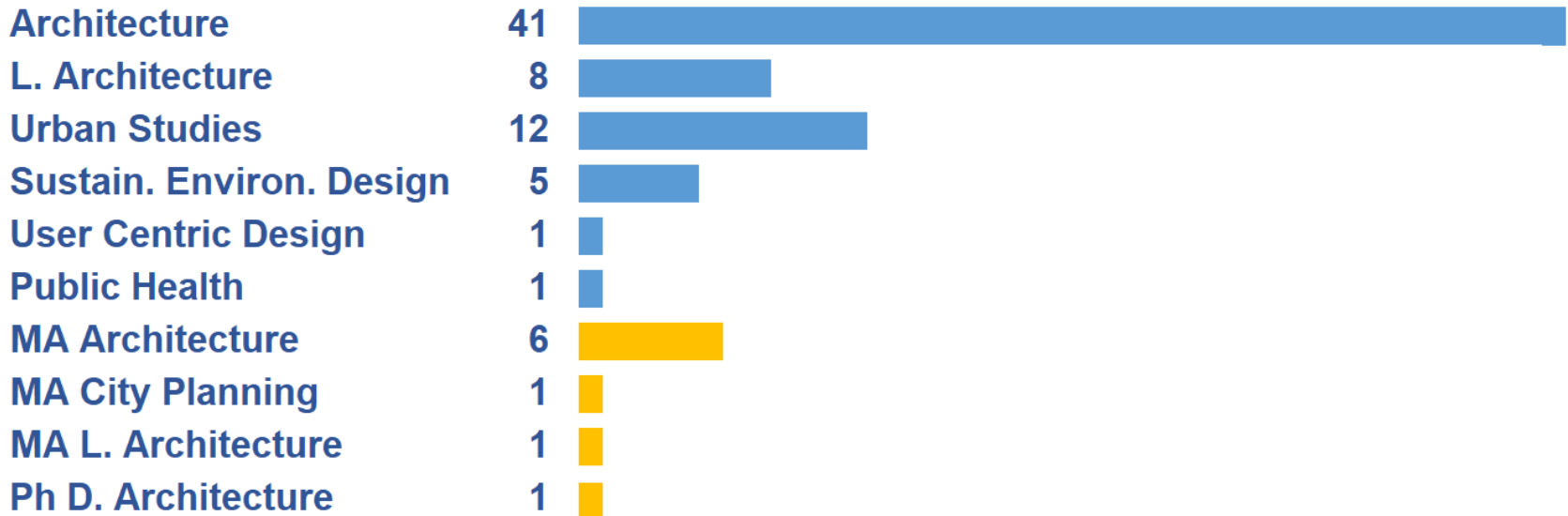

77





Martin Del Campo . Bob Esparza & Antonia Escobar Prizes

Academic & Creative Excellence

# Scholarships (\$): Men & Women

## LEGEND

	Men	18,100	34.80%
	Woman	33,900	65.20%
<b>Total</b>		<b>52,000</b>	<b>100%</b>

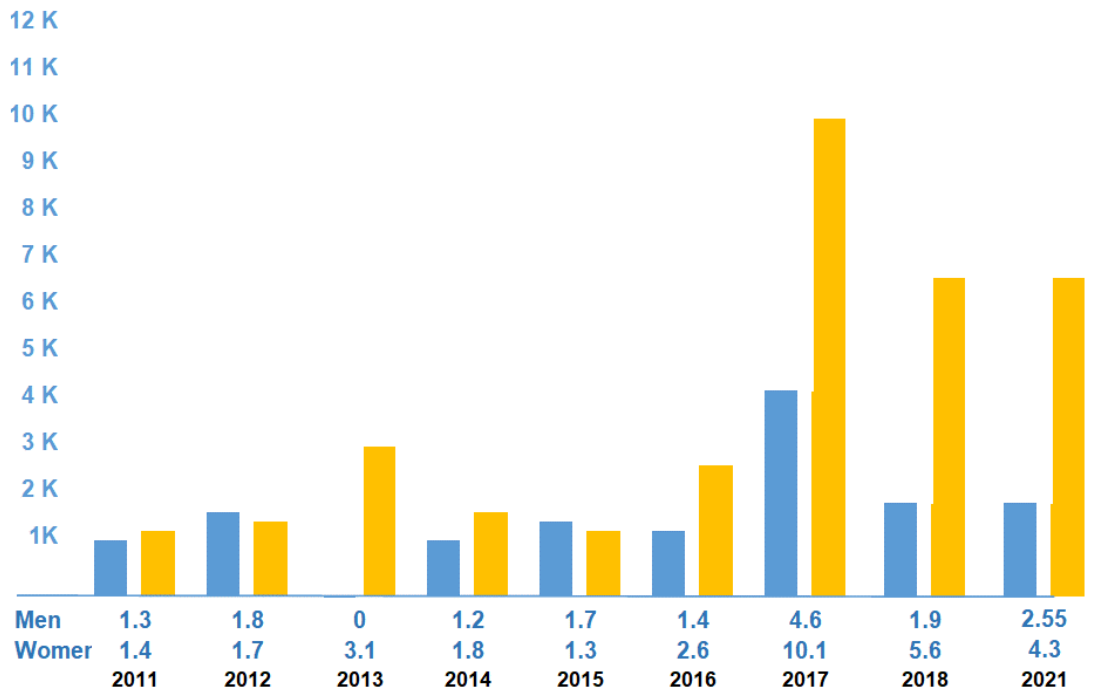



Martin Del Campo . Bob Esparza

& Antonia Escobar Prizes

A c a d e m i c & C r e a t i v e E x c e l l e n c e

## 2021 Scholarship Contributions:

**Sincere thanks  
to our  
generous  
donors!**

▪ Prof. David Diaz	100
▪ Michael Dear	250
▪ Prof. Jennifer Wolch	250
▪ Joseph Martinez	500
▪ Charles Higuera	750
▪ S. H. Cowell Foundation	1,500
▪ Roy Hernandez / ThirdWave	4,000
	<hr/>
	<b>\$ 7,350</b>

# SCHOLARSHIP AWARDS





Martin Del Campo . Bob Esparza

& Antonia Escobar Prizes

A c a d e m i c & C r e a t i v e E x c e l l e n c e



*When I think about the future, I only envision working hard, but I do hope to travel and move to another place to explore opportunities. I know thanks to CED and CASA, my dreams will become possible.*

## **Anthony Gonzales**

BA Architecture 2023

- Born and raised in McFarland, CA
- Raised by a wonderful single mother
- Idea to study architecture came in 8<sup>th</sup> grade
- Plans to go to grad school

## **Merit Award**

\$ 250



Martin Del Campo . Bob Esparza

& Antonia Escobar Prizes

## Model Building with Josef Albers Painting

Course: 21094

Prof.: Rudabeh Pakrvan

This Drawing is a model of a building design I created by extruding and cutting from shapes that came from a Josef Albers painting. This model consists of three floors and a courtyard in the middle of the building.

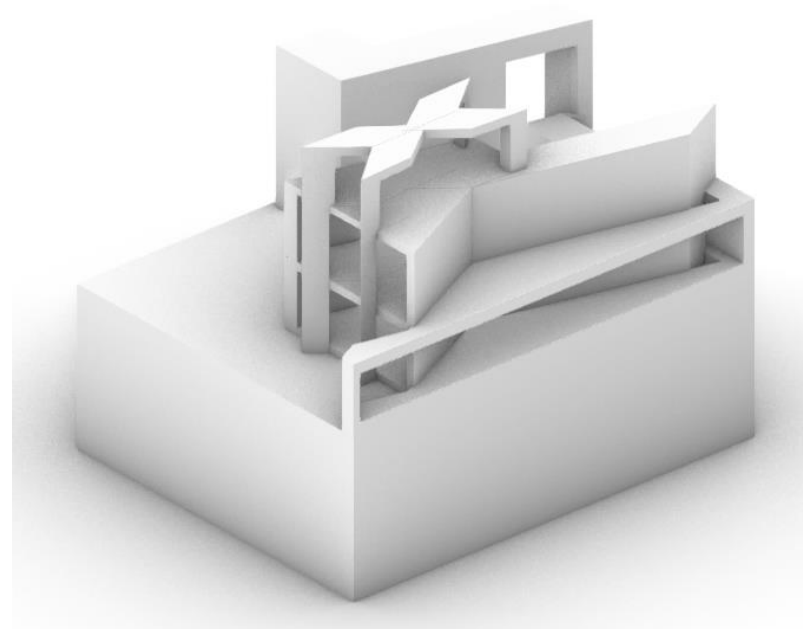
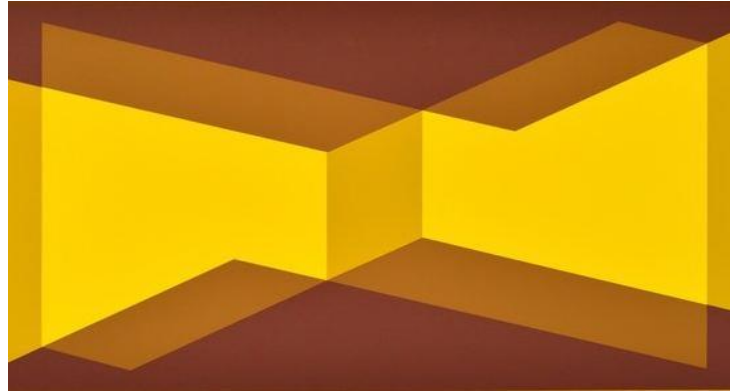



Martin Del Campo . Bob Esparza

& Antonia Escobar Prizes

A c a d e m i c & C r e a t i v e E x c e l l e n c e



*In 5 years, I see myself working at a great firm on projects that excite me. I'd like to be part of a team that is motivated by the same principles as I am (combating gentrification and the effects of climate change).*

## Sunny Zhong

BA Architecture 2021

GPA: 3.51

- Born and raised in San Francisco
- Raised by a wonderful single mother, low income
- Focus on affordable housing
- Mentored students on Rhino at CED
- Wants to start a firm in the future

## Merit Award

\$ 250





Martin Del Campo . Bob Esparza

& Antonia Escobar Prizes

## Noncontact Sanctuary

Course: ARCH 100C

Prof.: Mia Zinni

A noncontact, COVID-19 friendly sanctuary for people who have been traumatized by domestic abuse.





Martin Del Campo . Bob Esparza

& Antonia Escobar Prizes

A c a d e m i c & C r e a t i v e E x c e l l e n c e



*I am brown like my ancestors.  
Mexican like my parents.  
American like their dreams. I am  
Barrio Logan. My neighborhood  
has endured more than most  
people know.*

## **Alexandra Morales**

BA Urban Studies 2023

GPA: 3.51

- Latinx, women, working-class
- Commuted 4 hours every day for 11 years to go to a good school
- Director of Activism and Advocacy for the Berkeley Urban Studies Student Association (BUSSA)
- First-generation student to go to college

## **Merit Award**

\$300



Martin Del Campo . Bob Esparza

& Antonia Escobar Prizes

## Unhealthy Hoods: Rezoning our Streets for Justice

Course: CYPLAN 118AC: The Urban Community  
Professor: Ricardo G. Huerta Nino, Renee Roy Elias

Research to provide a city planning report on a solution-centered project that addressed an urban problem, Barrio Logan, environmental racism that resulted from discriminatory zoning practices.

While this was published in 2003, this image of Barrio Logan is nearly identical to today's image.



Figure 3: Image above shows children playing in a park in Barrio Logan with an oil processing plant only a few feet away.

Conclusively, Barrio Logan is a microcosm of environmental racism. For decades, Barrio Logan has resented these violent decisions that resulted in the mixed land-use space and displacement. Protests, demonstrations, and grassroots mobilization continue to respond to the marginalization of this community.

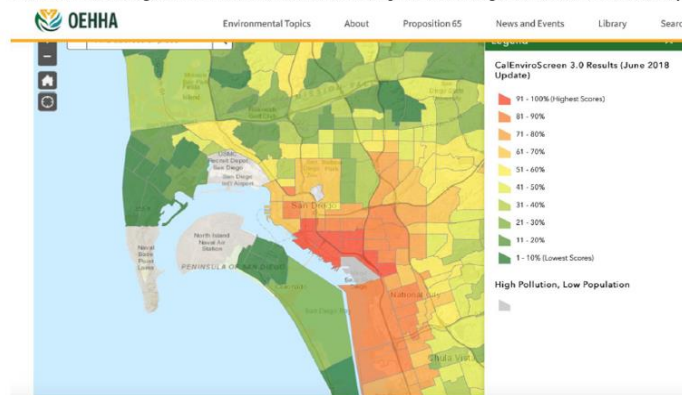



Martin Del Campo . Bob Esparza

& Antonia Escobar Prizes

**A c a d e m i c   &   C r e a t i v e   E x c e l l e n c e**



*I fell in love with the built environment as a child and felt that passion as I got older because architecture takes a toll on all our senses.*

## **Sulem Hernandez**

B.A. Arch, Sustainable Design 2023

GPA: 3.5

- Born and raised in Bakersfield, CA
- Raised by a wonderful single mother
- First generation immigrant, low income
- CASA, Outreach Chair
- Hermanas Unidas de UC Berkeley, Treasurer

## **Merit Award**

**\$300**



Martin Del Campo . Bob Esparza

& Antonia Escobar Prizes

## Critical Idea Void

### Architecture 11B

Professor: Rudabeh Pakravan,  
Department of Architecture

Create a design from a painting to emphasize from it. I decided to emphasize what is seen as solid in the painting as a void space and take those hollow shapes and make them into 3D geometric forms. I designed my building and wrapped it around this central void that goes into the ground plane. I added that the last floor before the void. I see it as a courtyard that showcases this central void through the usage of natural sunlight.

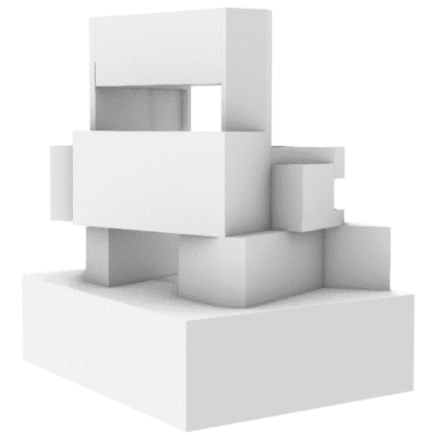
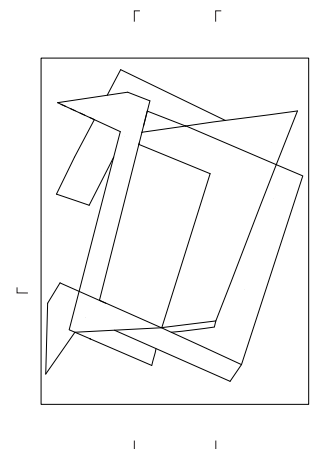
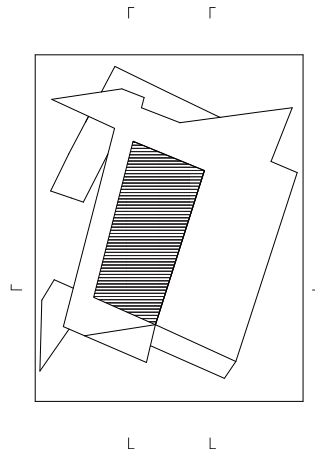
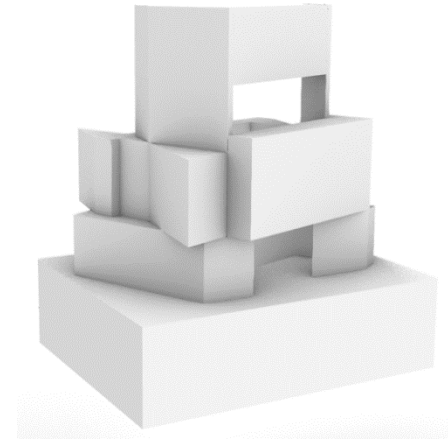
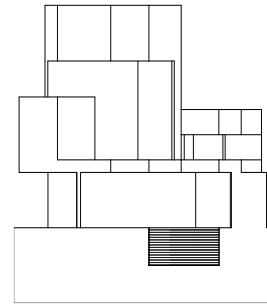
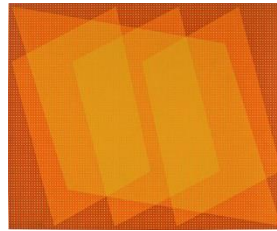





Martin Del Campo . Bob Esparza

& Antonia Escobar Prizes

A c a d e m i c & C r e a t i v e E x c e l l e n c e



*Regardless of the firm, large or small, I will be involved in community-based projects, taking on challenges that must be overcome in order to progress.*

## **Juan Jose Ramos de Reza**

BA Architecture 2021

- From Fresnillo, Zacatecas, Mexico
- First generation, Dreamer
- Relaunched CASA (with Omar Martinez)
- CASA Community Service Chair
- CASA Digital Marketing Chair
- CASA Finance Chair

## **Merit Award**

\$300





Martin Del Campo . Bob Esparza

& Antonia Escobar Prizes

## K-12 Outdoor School

### ARCH 100C

Professor: Lisa Iwamoto

The design for an open air k-12, school in Mission Bay, SF is the tangential relationships between linear and circular. The first relationship is between the site boundary and large elliptical form housing the school programs. The ellipse was distorted to tangentially meet site boundaries, to occupy as much area as possible. A similar ellipse of a smaller scale was voided in the mass to produce the central green space, while others are used to pierce light through the building.

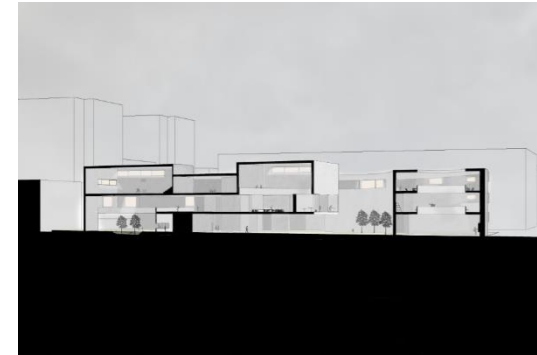
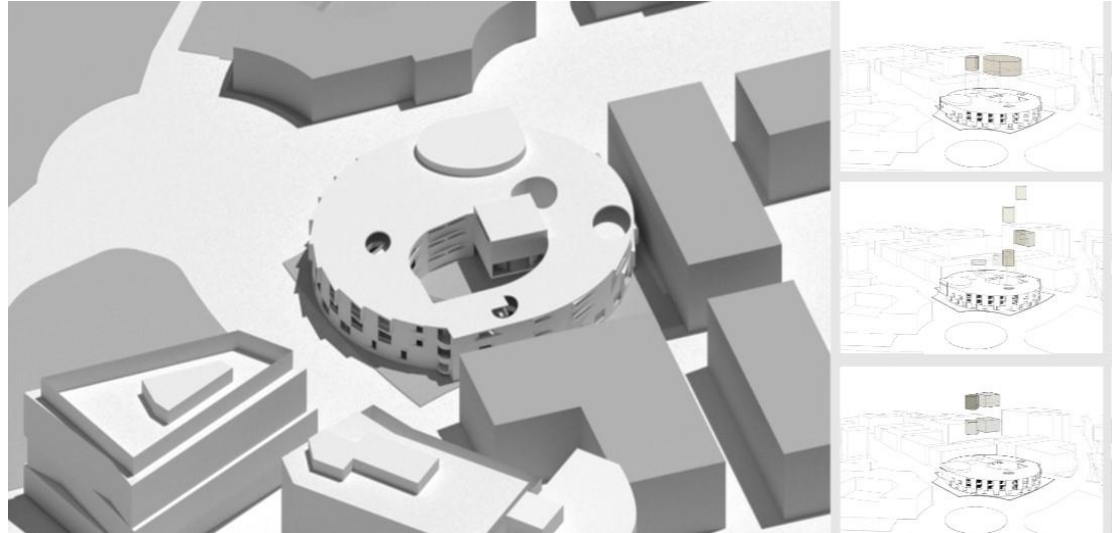



Martin Del Campo . Bob Esparza

& Antonia Escobar Prizes

A c a d e m i c & C r e a t i v e E x c e l l e n c e



*In 5 years, I see myself completing the requirements and exams to become a licensed architect. Since one needs work experience under a licensed architect, I also hope to gain many valuable lessons from working at a firm for a couple of years.*

## **Leslie Gonzales**

BA Architecture, 2022

- Born in Van Nuys, CA to immigrant parents
- CASA Community Service Co-Chair
- Newman Hall community, community outreach, retreats, and bible studies
- Want to become a licensed architect, design homes and hotels

## **Bob Esparza Scholarship**

\$400



Martin Del Campo . Bob Esparza

& Antonia Escobar Prizes

## Collective Form Fundamentals of Architectural Design / Arch 100A

Professor: David Orkand

This two-story community center investigates pinching moments that happen in different forms, leading to open spaces. They happen between two buildings that become a threshold on the ground level and where the second floor of the two buildings connect. This also happens on the interior with the orientation of the stairs and the exterior spaces that protrude into the building to create complex spaces within.

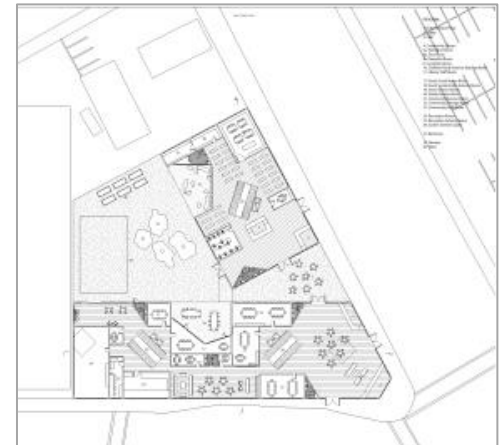
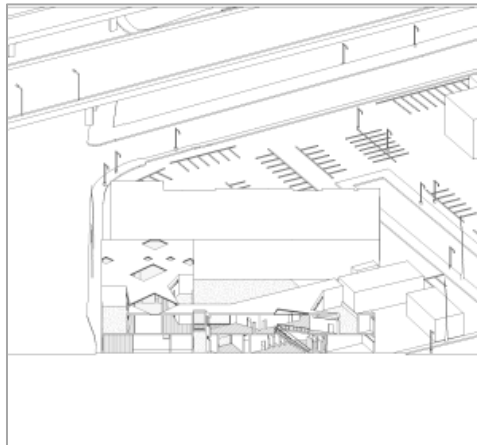
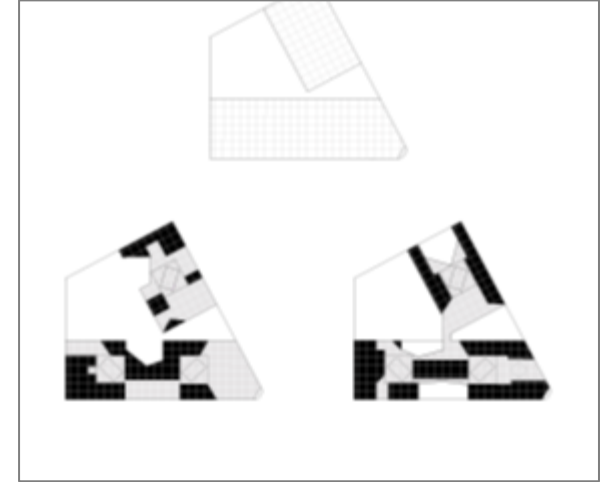
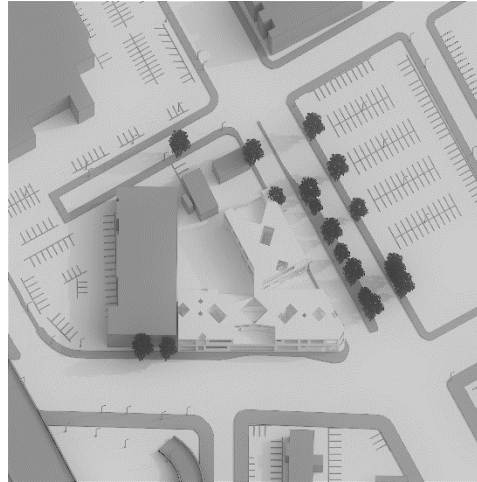



Martin Del Campo . Bob Esparza

& Antonia Escobar Prizes

## Projection Modulation and Spatial Construction

Introduction to Visual  
Representation and Drawing  
Arch 11A

Professor / Dept.: David  
Orkand

Created 8 individual cubes  
from projections, and  
rearranged them to create  
voids and continuity. I created  
a complex, windy model that  
accentuated key aspects [voids  
and continuity] from the  
previous assignment.

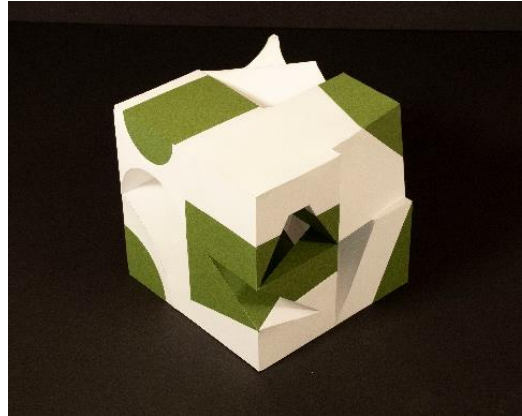



Martin Del Campo . Bob Esparza

& Antonia Escobar Prizes

A c a d e m i c & C r e a t i v e E x c e l l e n c e



## Marilyn Reyes

M Arch, 2022

GPA: 3.8

- Born in El Paso, Texas, raised in Ciudad Juarez, Chihuahua, Mex.
- Graduate Association of Latinx Students, formerly known as Graduate Students de la Raza
- CED Graduate Student Council Member

*In 5 years, I see myself developing skills and gaining knowledge in the architecture field. . . . by collaborating in a architecture practice that emphasizes social responsibility, sustainability, and environmental justice through design.*

## Martin Del Campo Scholarship

\$400





Martin Del Campo . Bob Esparza

& Antonia Escobar Prizes

## Infrastructure | Migration Trajectories

**Course: Architecture Design Studio 460**

Professor: Ersela Kripa | Texas Tech Univ. El Paso

Explore the bi-national landscape of the Chihuahuan Desert as a migratory path of Monarch butterflies. The region is located along the Monarch butterfly Spring Trail between Mexico, the U.S. and Canada.

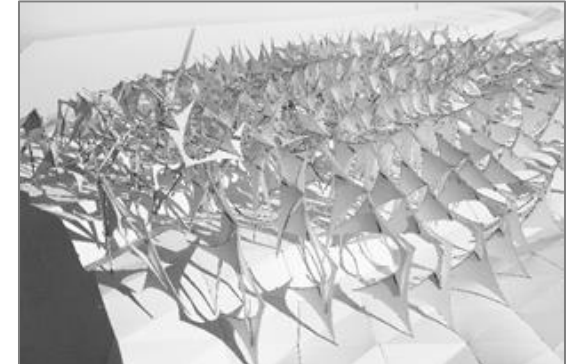
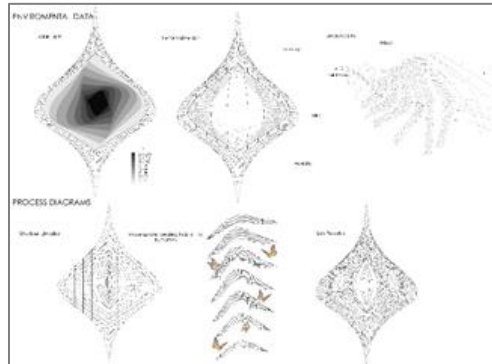
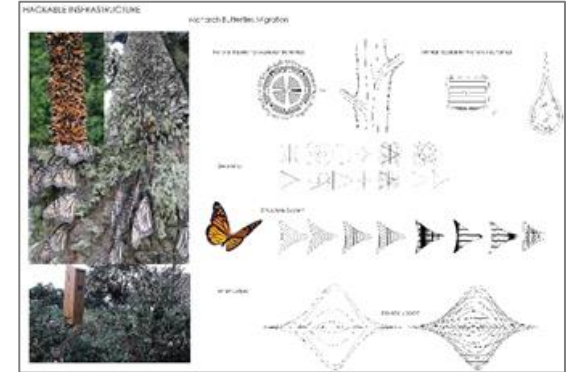
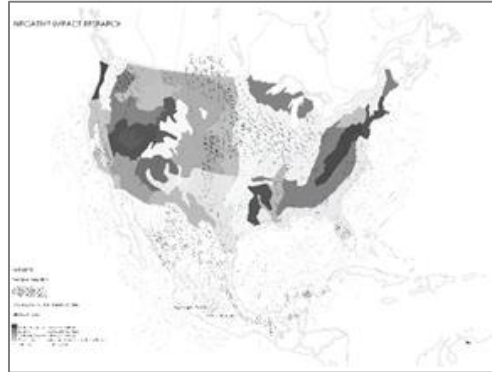



Martin Del Campo . Bob Esparza



& Antonia Escobar Prizes

A c a d e m i c & C r e a t i v e E x c e l l e n c e



*I see myself using my working in architecture or design to advocate for a more equitable future that places the health and well-being of low-income and BIPOC communities at the center of my focus, to empower and engage neighborhoods at all scales.*

## Samantha Andalon

BA Architecture, 2023

GPA: 3.935 Highest Honor Student

- CASA Vice President/Secretary
- Layout Designer for *The Daily Californian*
- *Graphic Design, The Rights Stuff*, a student-run publication focused on human rights
- Volunteer with the Berkeley Public Service's Los Angeles Urban Health Alternative Break program
- Look to pursue a Master's in Urban Design

## Bob Esparza Scholarship

\$400



Martin Del Campo . Bob Esparza

& Antonia Escobar Prizes

## Theodora

### Envdes1: Introduction to Environmental Design

Professor: Nathan John

My project focused on the development of the city of Theodora from Italo Calvino's work *The Invisible Cities*. I utilized collage in plan and section to capture the sterile, unnatural, and closed, maze-like surface of "The Human City", while forgotten memories of the natural realm (represented by the colored details) hide just below the surface, threatening to consume and reattack the land.

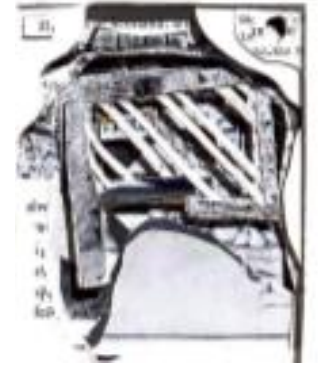
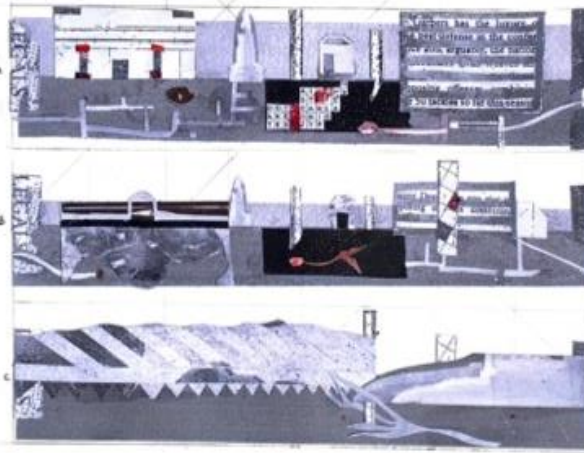



Martin Del Campo . Bob Esparza

& Antonia Escobar Prizes

## Hybridization

### 11A: Introduction to Visualization & Architectural Representation

Professor: Professor Maria Paz Gutierrez

Explored idea of pressure points and invisibility through a hybrid model. The original body analysis (A), explored how points of contact and levels of pressure between the object and the surface traveled, then represented in surveying drawing (B) through triangulation to capture the presence of these inherently invisible features. Transferred these ideas into building component survey (C), where the object's similar structure and curves to the body, introduced the concept of voids and volume into my process.

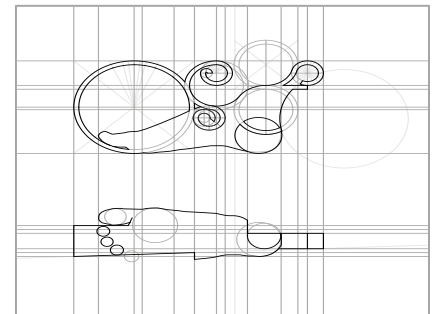
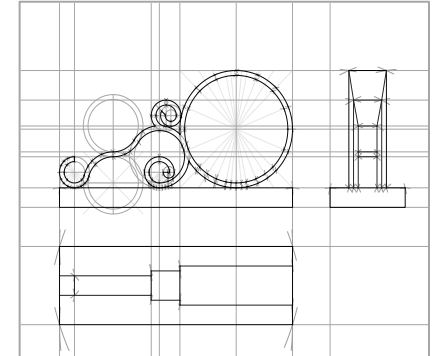
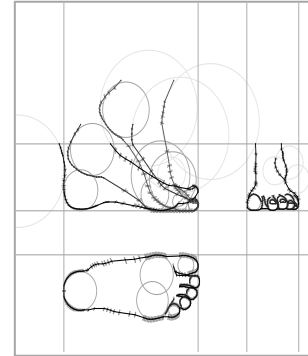



Martin Del Campo . Bob Esparza

& Antonia Escobar Prizes

A c a d e m i c & C r e a t i v e E x c e l l e n c e



*In 5 years, I see myself working on sustainability issues or climate adaptation projects either in the Bay Area or in another city on the West Coast.*

## **Michelle Hernandez**

BA Architecture, 2021

BPA: 3.7

- Born and raised in Berkeley, raised in Oakland, in a low income family
- Plan to work for a couple of years and then attend graduate school
- Current CASA President
- Contributing Writer to ByDESIGN

## **Martin Del Campo Scholarship**

**\$750**





Martin Del Campo . Bob Esparza

& Antonia Escobar Prizes

## Ward to Blake Street Proposed Streetscape Configuration

### City Planning 1540

Professor: Zachary Lamb

This proposed streetscape intervention identifies the lack of pedestrian prioritization on this section of Shattuck Avenue, making it a dangerous area to cross the street or use alternative transportation methods. The design narrows the car lanes, adds protected bike lanes, expands pedestrian islands and sidewalks in order to slow down traffic while enhancing the pedestrian experience within these blocks.

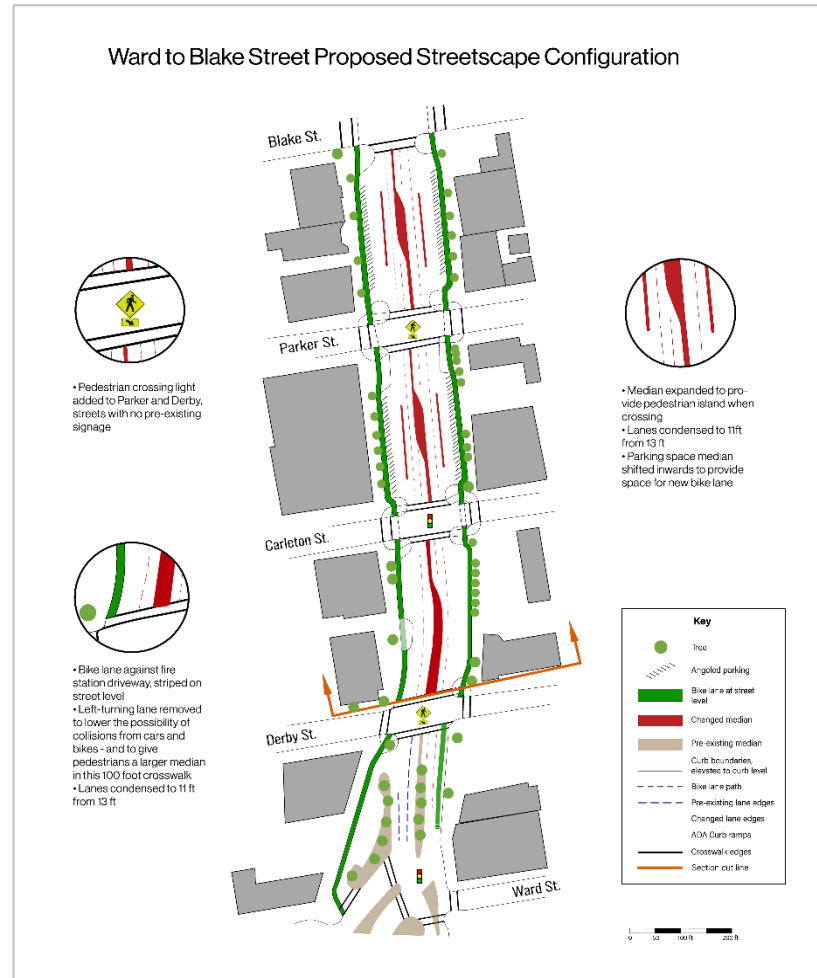



Martin Del Campo . Bob Esparza

& Antonia Escobar Prizes

A c a d e m i c & C r e a t i v e E x c e l l e n c e



## Jennifer Recinos

BA Architecture, 2021

- Immigrated from Guatemala at 5, first-generation, low-income
- CASA President, Community Service Chair
- Educational Opportunity Program (EOP) Intern
- Contributing Writer to ByDESIGN

## Antonia Escobar Prize

\$750

*I hope to be in a firm that gives me the opportunity to engage in impact-oriented design, allowing affected communities to voice their opinions, promote accountability, and ensure community benefits and safety ...*



Martin Del Campo . Bob Esparza

& Antonia Escobar Prizes

A c a d e m i c & C r e a t i v e E x c e l l e n c e

## Domestic, Non-Contact Sanctuary in Oakland

**Course: Architecture 100C**

Professor: Mia Zinni

Gender-based violence is a sensitive, yet common violation that is quite ignored in considering creative solutions around ways of retreating and restoring. This impact-oriented design promotes ways of how macro and micro scales of a shelter provide secured opportunities for victims (women, men, and non-gender conforming) of domestic violence to heal and create outlets for communal growth.







Martin Del Campo . Bob Esparza

& Antonia Escobar Prizes

A c a d e m i c & C r e a t i v e E x c e l l e n c e



*Beyond design, architecture to me encompasses a broad array of entities centered on tracks of urbanism, sustainability, history, building technology, social sciences, and so much more.*

## **Andrea Hernandez**

BA Architecture. 2021

GPA: 3.87 Honor Student

- Grew up in East Los Angeles, daughter of Immigrants, low income
- Committee Chair, Cal Rotaract, nationwide organization focusing on community work and high school mentorship programs
- Reinstated CASA in 2019
- CASA Academic Chair
- CED's Career Center

## **Antonia Escobar Prize**

\$1,000



Martin Del Campo . Bob Esparza

& Antonia Escobar Prizes

## Non-Contact Domestic Violence Sanctuary

**Course:** ARCH 100C

**Professor:** Mia Zinni

In a year of unprecedented changes, the outbreak of COVID-19 posed a critical question in the design of transitional and supportive housing. Located on Broadway and Webster in Oakland California, this domestic violence (DV) sanctuary addresses concerns around non-contact while simultaneously creating a space for retreat, restoration, peace, and solace. The DV sanctuary promotes the concept of non-contact spaces by seeking to restore the connection to the outdoors. Increasing the ratio of outdoor areas to interior programs allowed the design of private, intimate spaces for retreat and healing while also limiting physical contact.

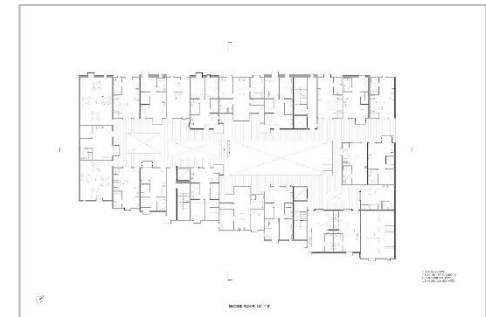



Martin Del Campo . Bob Esparza & Antonia Escobar Prizes



Martin Del Campo . Bob Esparza



& Antonia Escobar Prizes

A c a d e m i c & C r e a t i v e E x c e l l e n c e



*In five years, I see myself working and teaching in the architecture practice. I want to pursue a masters in Architecture and Urban Design to better understand the relationship of cities, and design in their contribution to urban communities.*

## Omar Martinez-Zoluaga

BA Architecture, 2021

- Born in Puebla, Mexico, grew up in South Central LA
- Led the rebuilding of CASA in 2019 at CED
- Co-hosted professional and academic events, grew the membership to the largest in 50 years
- Hermanos Unidos and Rising Immigrant Scholars Through Education
- Want to pursue M. Arch and Urban Design

## ThirdWave Excellence Award

\$1,000





Martin Del Campo . Bob Esparza

& Antonia Escobar Prizes

A c a d e m i c & C r e a t i v e E x c e l l e n c e

## MERGE

Arch 109

Andrew Atwood / Architecture

The Merge, located on Wilshire Blvd in Los Angeles, CA is an extension of the Los Angeles Art Museum. This project was inspired by Steven Holl's Horizontal Building, and Johnston's Marklees' Menil Art Institute. The concept merge was pursued by the use of parallel tubes that contained a series of volumes – what happens when program meets program? What potential does the combination of two different programs allocate? The overlapping of volumes created opportunities for major public programs, creating fluidity among volume and volume.

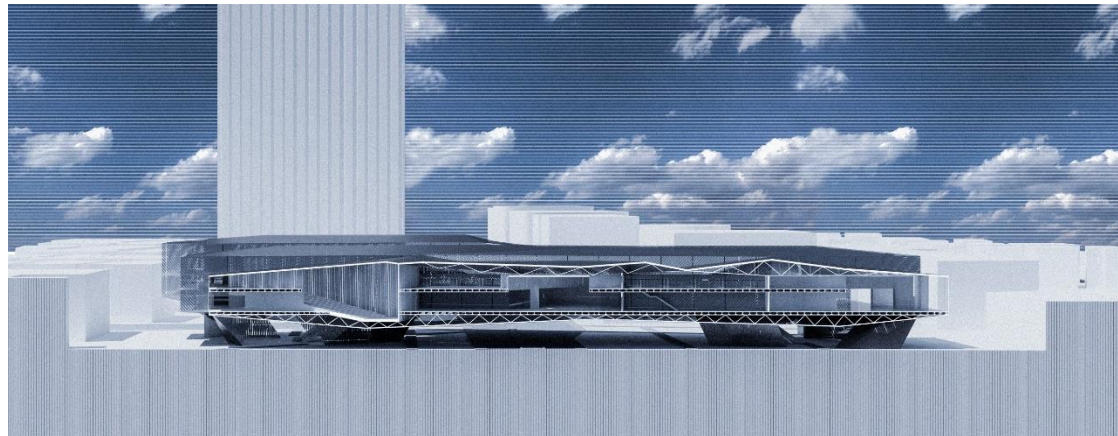
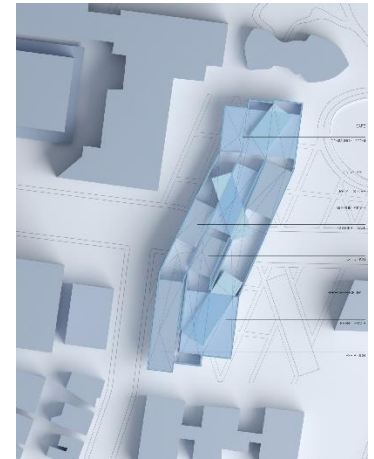
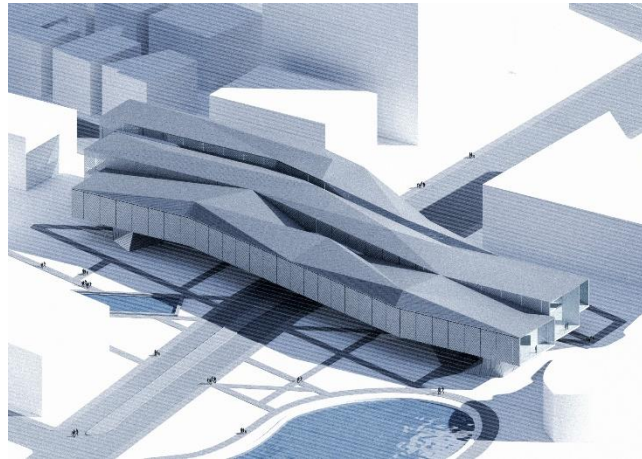



Martin Del Campo . Bob Esparza

& Antonia Escobar Prizes

A c a d e m i c & C r e a t i v e E x c e l l e n c e



*In 5 Years: Completing my dissertation and perhaps working my way into university teaching and museum curatorial worlds at SF MoMA or MoMA in NYC. (Fingers crossed!)*

## **Ivan-Nicholas Cisneros**

BA Architecture, UC Berkeley

M. Arch & Urban Planning, Princeton

Ph D, Columbia University

- Born in Compton and grew up in Fontana, CA , one of six siblings
- First generation, low income, first in family to get a Masters, PhD Latin-American Modernism in North/South America

## **Martin Del Campo Scholarship**

\$1,000



Martin Del Campo . Bob Esparza

& Antonia Escobar Prizes

A c a d e m i c & C r e a t i v e E x c e l l e n c e



CASA Alumni Scholarships  
CED UC Berkeley  
April 20, 2011

Querido Roy,

I wanted to share some really amazing news! I was admitted and just accepted my offer to the M.Arch program at Princeton!! I was deciding between that and the Architectural Association in London. I still have an interview tomorrow afternoon with the Bartlett at UCL in London.

I wanted to thank you and CASA Alumni for giving us so much support during and after our education at Berkeley. During my time in school, I was going back and forth on whether I was even good enough to complete my undergrad degree and really did not think I had what it took to complete the program. It was after the CASA awards in the spring of 2012, when I was surprised to find out I won a scholarship, that I started to believe in myself.

Once that started, I found myself winning other awards and next thing you know I was the speaker at graduation! I still cannot believe I'm headed to Princeton this fall. I will forever be thankful to you and the rest of the CASA Alumni for believing in me and igniting a fire in me that has gotten me this far.

Ivan-Nicholas





Martin Del Campo . Bob Esparza

& Antonia Escobar Prizes

A c a d e m i c & C r e a t i v e E x c e l l e n c e



PRINCETON  
UNIVERSITY



COLUMBIA  
UNIVERSITY



# Estamos orgullosos de ustedes!

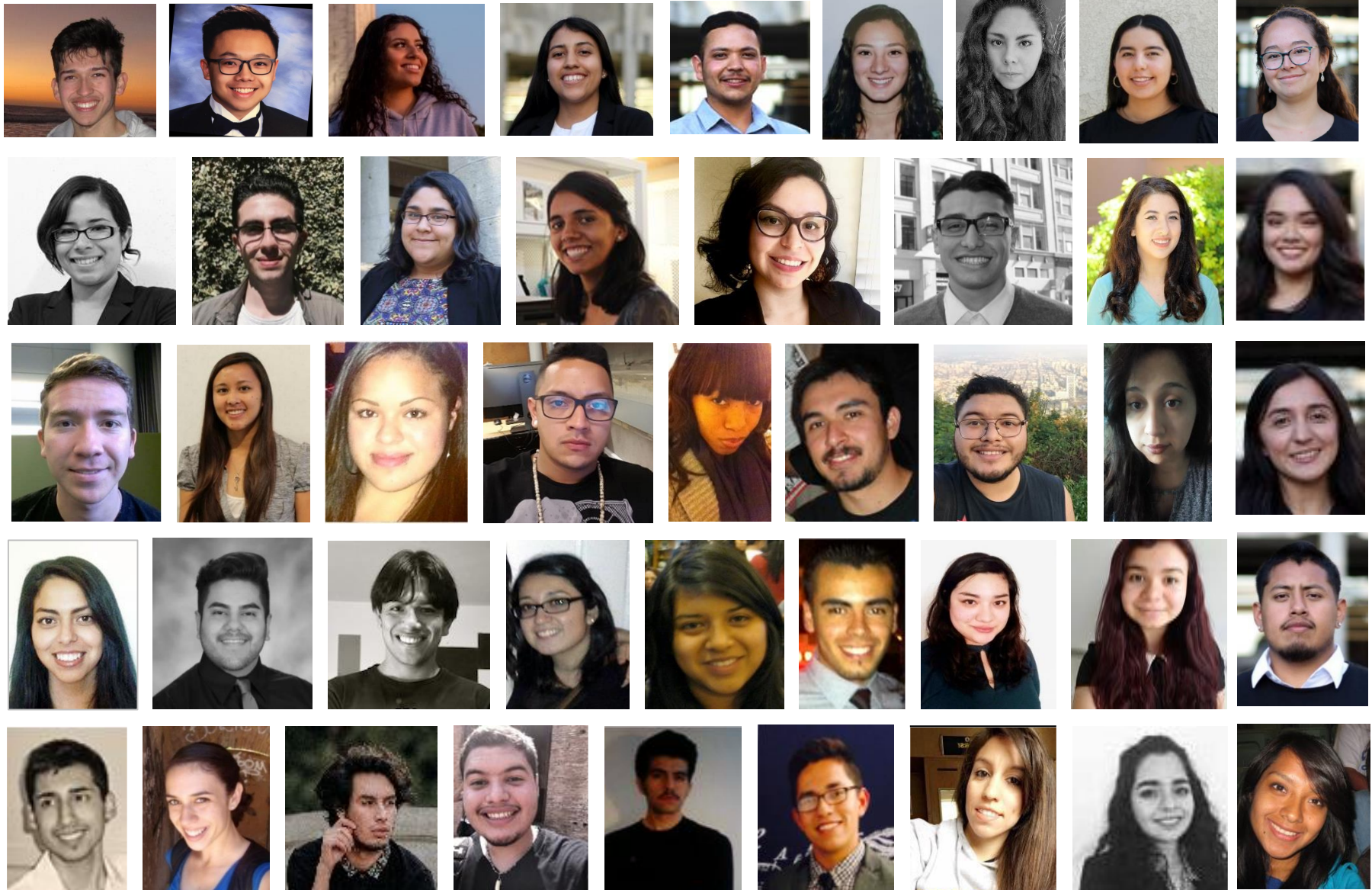



## CASA Alumni Scholarships

**Send donations to:** The Center for Architecture + Design  
Attn: CASA Alumni Scholarship  
130 Sutter St, Suite 600, San Francisco, CA 94104

**Make checks payable to:**  
Center for Architecture + Design  
Check subject line: CASA Alumni Scholarship  
Tax ID# 20-2434734

**Roy Rogelio Hernández**  
roy.hernandez@thirdwavecorp.com  
310.804.7565



Thanks for supporting the Dream!

Good night, be safe.

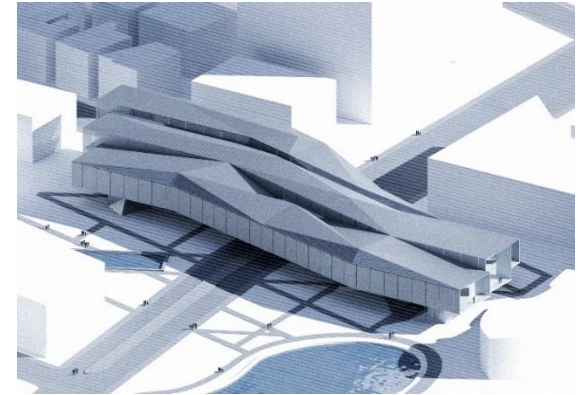
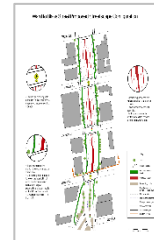
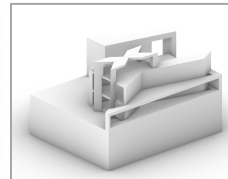



## ByDESIGN

12100 Wilshire Blvd., Suite 800  
Los Angeles, CA 90025  
[www.bd-zine.org](http://www.bd-zine.org)  
[www.casa-ucberkeley.com](http://www.casa-ucberkeley.com)

**Roy Rogelio Hernández**

Founder / Publisher

[roy.hernandez@thirdwavecorp.com](mailto:roy.hernandez@thirdwavecorp.com)

310.804.7565

**Joseph Martinez, Architect**

Sr. Editor

[jpmartinez.sr@gmail.com](mailto:jpmartinez.sr@gmail.com)